

SPAN TABLE Southern Forest Products specifications for no. 2 grade fir or yellow pine

CEILING JOISTS (LIMITED ATTIC STORAGE)	FLOOR JOISTS (40 psf LIVE LOAD)	RAFTERS (SLOPES OVER 3:12)	HEADERS
2x6 at 16" O.C. = 13'-2"	2x12 at 24" O.C. = 15'-4"	2x6 at 24" O.C. = 11'-4"	2-2x4 on edge = 3'-6"
2x8 at 16" O.C. = 17'-5"	2x12 at 16" O.C. = 18'-10"	2x6 at 16" O.C. = 13'-11"	2-2x6 on edge = 4'-6"
2x10 at 16" O.C. = 20'-9"	2x12 at 12" O.C. = 21'-7"	2x6 at 12" O.C. = 16'-11"	2-2x10 on edge = 7'-6"

HEADER SCHEDULE #2 Y.P. or better

SPAN (MAX.)	3'-6"	6'-0"	8'-0"	12'-0"	14'-0"
HEADER SIZE	2-2x4	2-2x6	2-2x8	2-2x10	2-2x12

Use 2-2x12 with 1/2" steel fitch plate, thru bolted for spans up to 20'-0"

FRAMING NOTES

- All bottom plates that contact concrete shall be CGA "treated" lumber.
- All wall studs shall be 2x4 at 16" on center unless noted otherwise.
- 1x4 yellow pine "let-in wind-bracing" shall be used in all interior walls wherever possible. Typically, interior walls longer than 8' shall include a diagonal wind-brace.
- Exterior sheathing shall be 7/16" oriented strand board (OSB) with applied anti-air infiltration house wrap.
- Headers, joists and rafters shall be sized according to the Span Table above or by using the span table provided by the City Building Inspections Department.
- All ridges, hips, and valleys shall be one size larger than rafters.
- Roof system shall include 7/16" OSB, 15# felt, and 25 yr. dimension type comp. shingles.
- Blocking shall be provided in appropriate locations.
- Provide 2x6 rafter ties at all plates where joists run perpendicular to rafters.
- Provide 2-2x6 strong back at spans over 10'-0"
- Fascia shall be 1x6 "Hardie" trim with 1x4 "Hardie" shingle mold and galv. 1x2 metal edging.
- Soffits shall be vented "Hardie" soffit.
- HVAC subcontractor shall design HVAC system and duct layouts. HVAC and plumbing subcontractors shall coordinate any special framing requirements such as attic equipment platforms, attic walkways, furr-downs, etc. with the framing subcontractor.
- HVAC subcontractor shall install required appliance vent ducting and other misc. ducting according to city and manufacturer's recommendations.

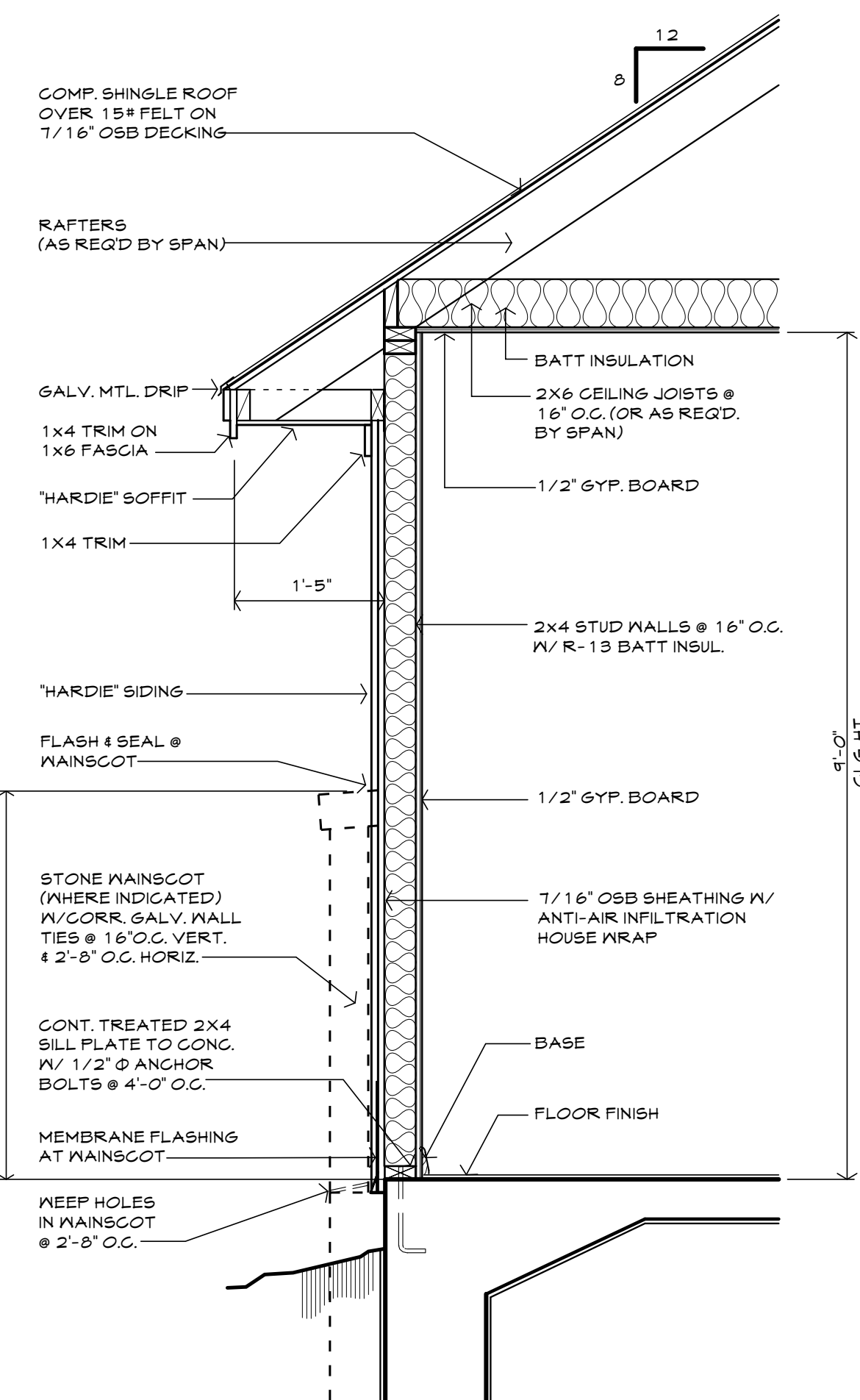

2 WALL SECTION
3/4" = 1'-0"

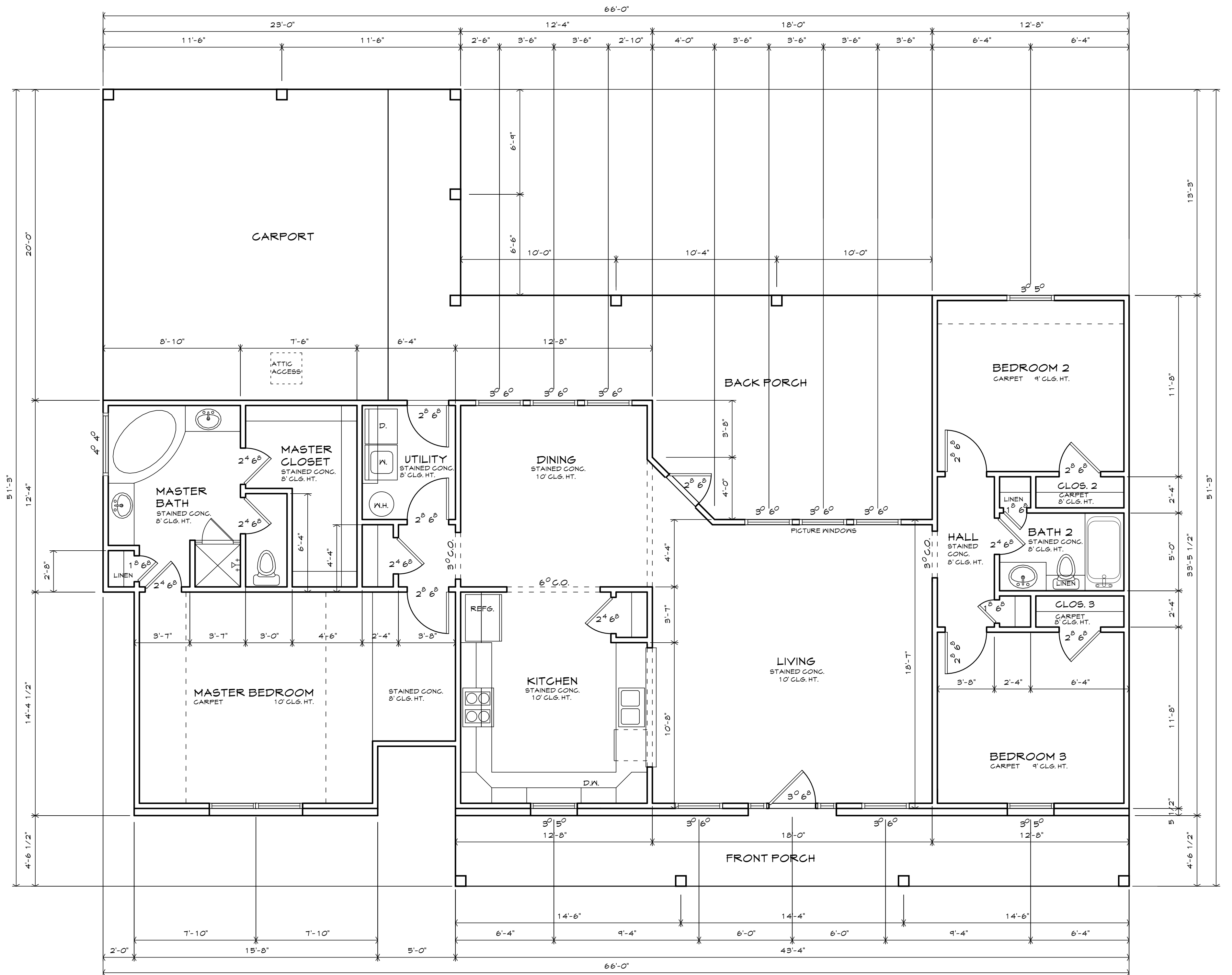

1 FLOOR PLAN
1/4" = 1'-0"

HEATED AREA:	1641 sf.
MASONRY:	22
FRONT PORCH:	197
BACK PORCH:	339
CARPENT:	460
SLAB AREA:	2659 sf.

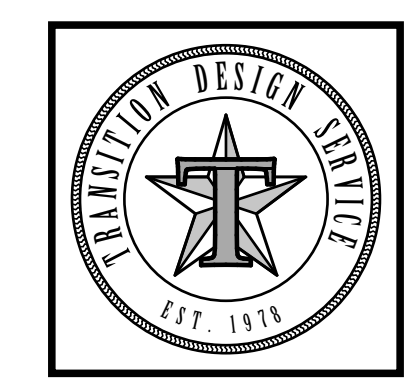

A NEW HOME FOR
JAMES YOUNG
COLLEGE STATION TEXAS
Transition Design Service
201 W. Villa Maria Road * Bryan, Texas 77801 * (979) 822-7777

DATE JAN. 2013

A 1

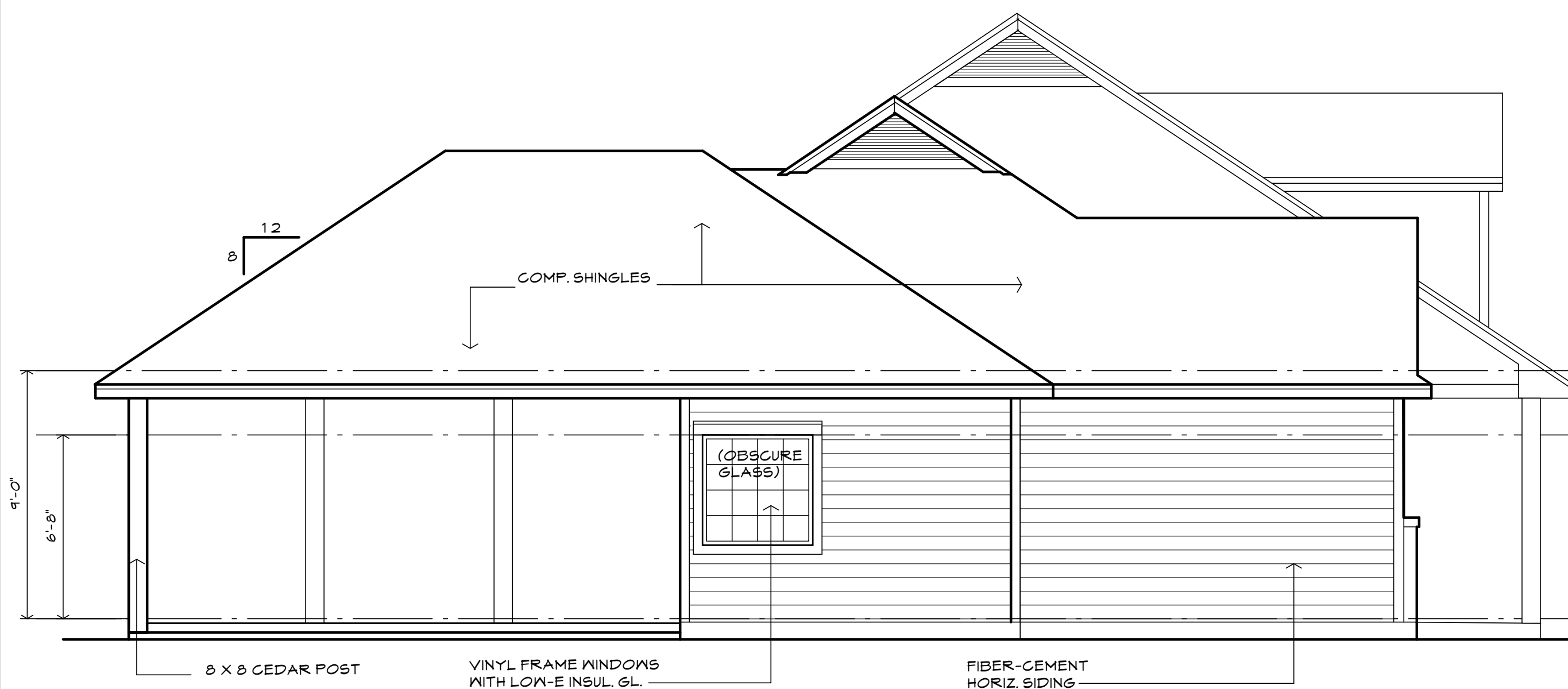

4 LEFT SIDE ELEVATION

1/4" = 1'-0"

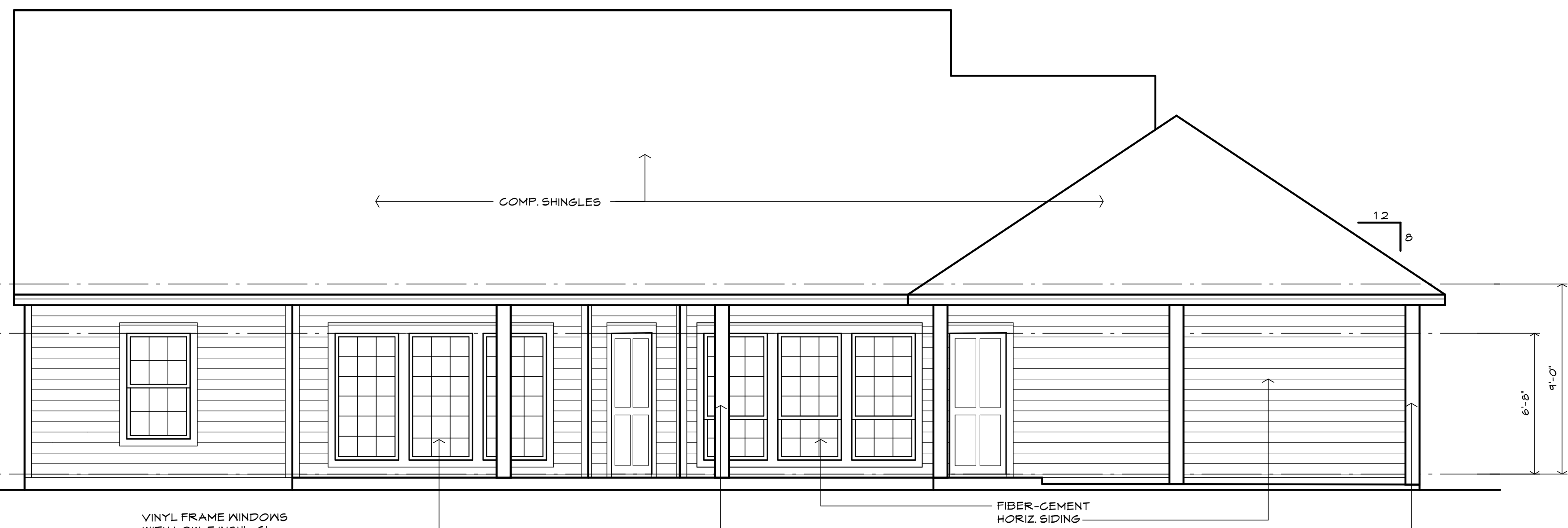

2 BACK ELEVATION

1/4" = 1'-0"

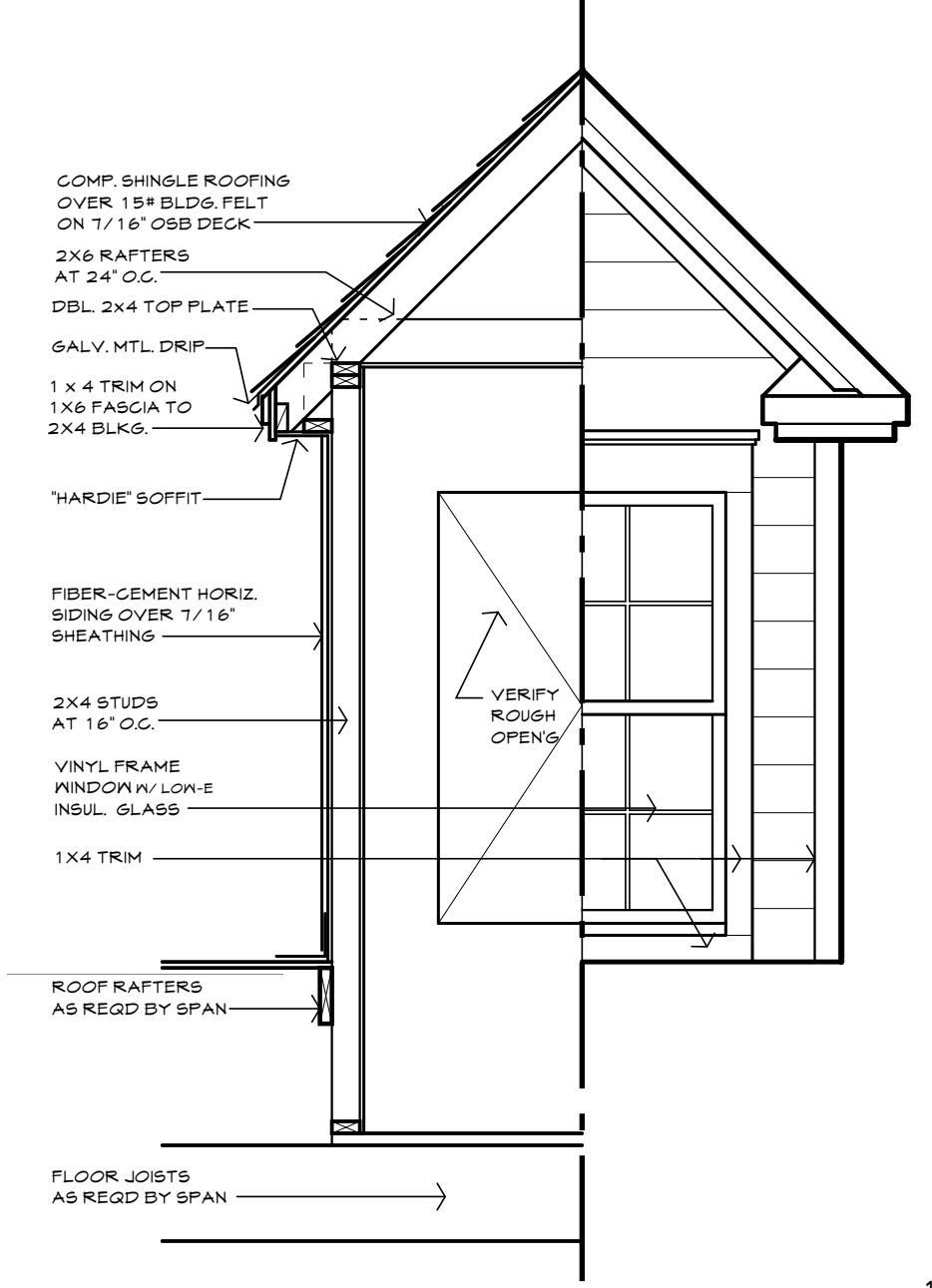

3 RIGHT SIDE ELEVATION

1/4" = 1'-0"

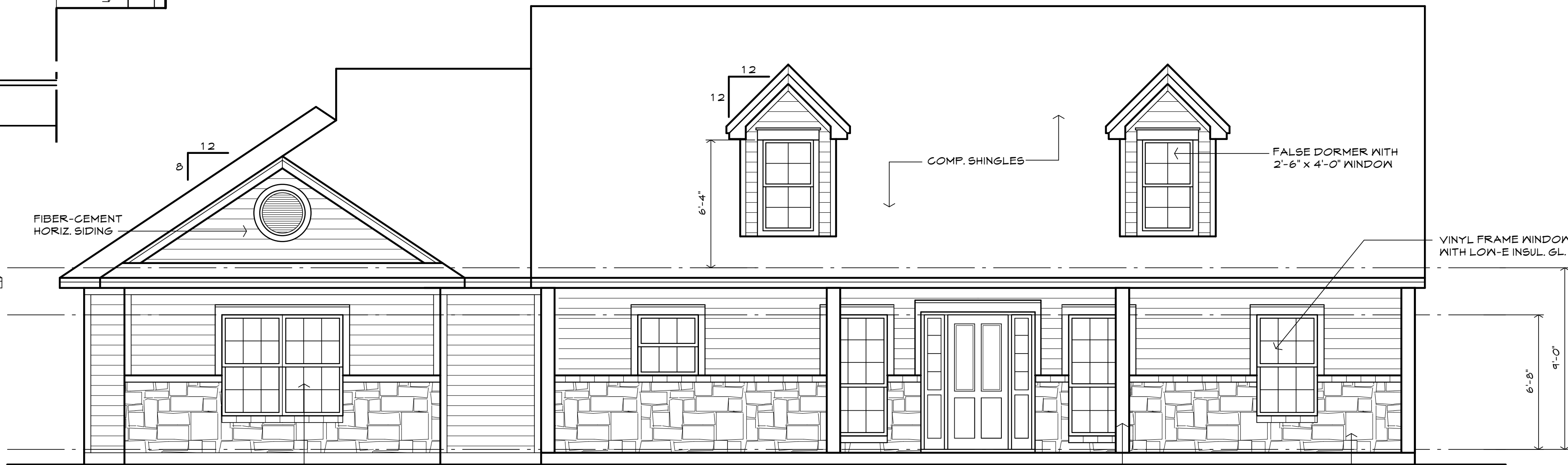





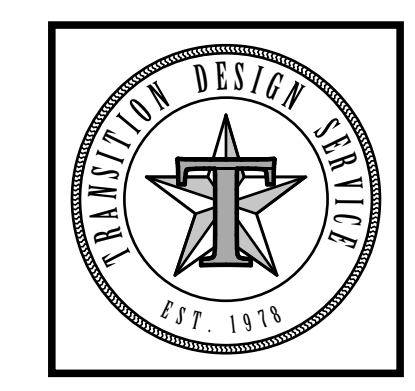













1 FRONT ELEVATION

1/4" = 1'-0"



A NEW HOME FOR
JAMES YOUNG
 COLLEGE STATION TEXAS
Transition Design Service
 201 W. Villa Maria Road * Bryan, Texas 77801 * (979) 822-7777

DATE JAN. 2013
A2

- ELECTRICAL LEGEND**
-  SECURITY LIGHT
 -  DUPLEX OUTLET
 -  GROUND FAULT ISOLATED OUTLET
 -  WATERPROOF DUPLEX OUTLET
 -  SPECIAL PURPOSE OUTLET
 -  DUPLEX FLOOR OUTLET
 -  TELEPHONE JACK
 -  CABLE OUTLET
 -  SWITCH
 -  3-WAY SWITCH
 -  SURFACE MOUNTED INCANDESCENT
 -  PENDANT MOUNTED INCANDESCENT
 -  RECESSED INCANDESCENT
 -  EXHAUST FAN
 -  DOOR BELL
 -  DOOR BELL CHIMES
 -  SMOKE DETECTOR
 -  CEILING FAN w/ LIGHT KIT

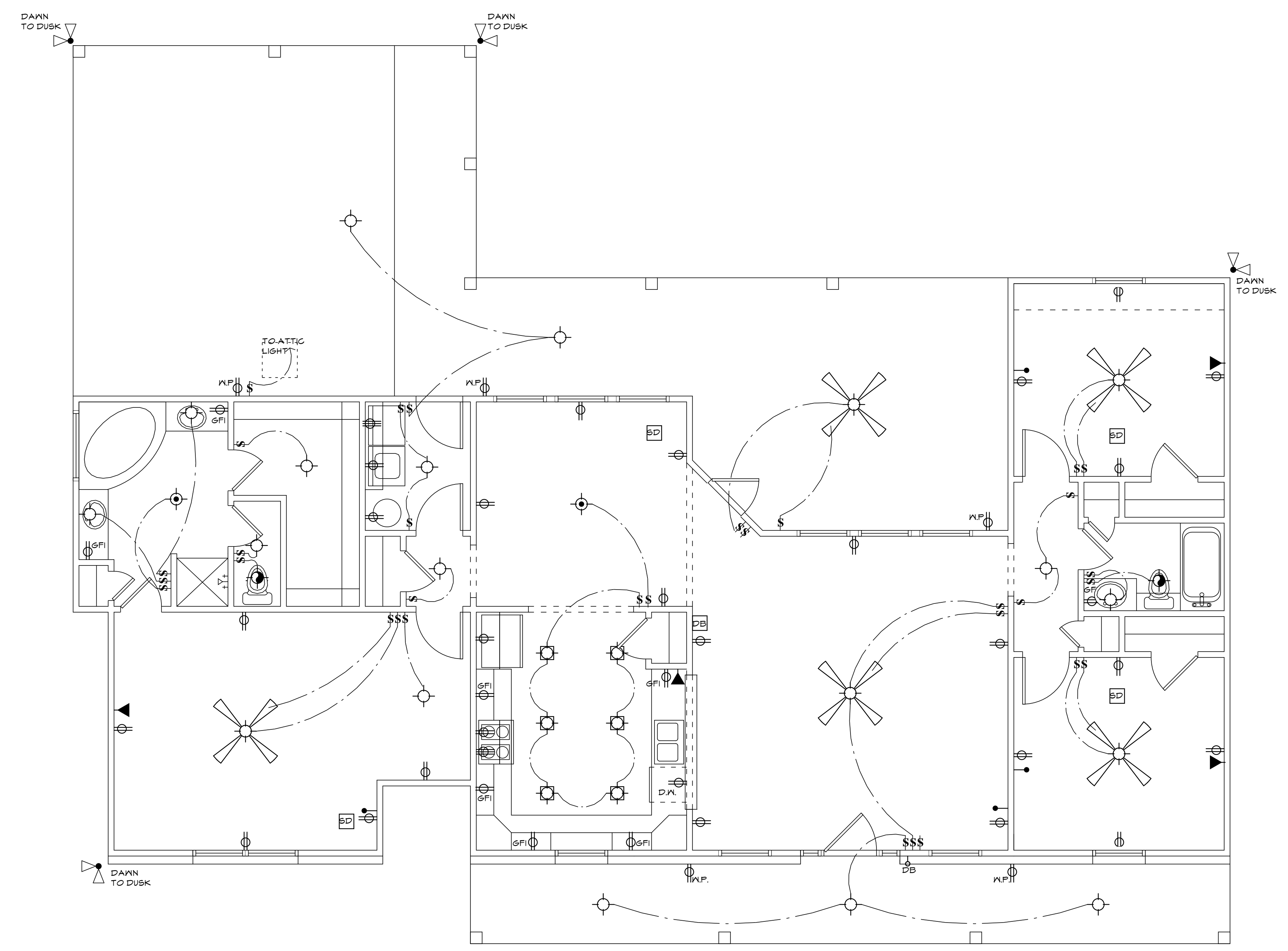

1 ELECTRICAL PLAN

1/4" = 1'-0"

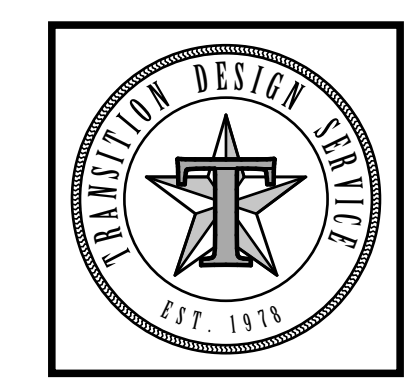

A NEW HOME FOR
JAMES YOUNG
 COLLEGE STATION TEXAS
Transition Design Service
 201 W. Villa Maria Road * Bryan, Texas 77801 * (979) 822-7777

DATE JAN. 2013
E 1

GENERAL RESIDENTIAL SPECIFICATIONS

- GENERAL**
- THE CONTRACTOR SHALL BE RESPONSIBLE FOR VERIFYING ALL DIMENSIONS PRIOR TO CONSTRUCTION AND FOR CHECKING ARCHITECTURAL VERSUS STRUCTURAL DIMENSIONS. THIS SHALL BE COMPLETED PRIOR TO COMMENCEMENT OF WORK. ANY DISCREPANCIES SHALL BE REPORTED TO THE ARCHITECT FOR CHECKING AND ALLOWANCES MADE FOR MINOR REVISIONS.
 - REFER TO ARCHITECTURAL DRAWINGS FOR FLOOR ELEVATIONS, SLOPED OR DEPRESSED FLOOR AREAS, FINISHES, BRICK LEDGES, ETC.
 - ALL SOIL UNDER SLAB SHALL BE TREATED WITH A 1% DURBAN TERMITICIDE TREATMENT, OR EQUAL BY A CERTIFIED APPLICATOR.
 - 6 MIL. POLYETHYLENE PLASTIC SHEETING SHALL BE RUN CONTINUOUSLY UNDER FOUNDATION AS A VAPOR BARRIER.
 - 1/2" x 8" ANCHOR BOLTS SHALL BE PLACED ON 48" CENTERS FOR ALL EXTERIOR WALLS.
 - FOUNDATION SHALL COMPLY WITH THE CITY OF COLLEGE STATION FOUNDATION STANDARDS.
- EXCAVATION & FILL**
- BOTTOMS AND SIDES OF EXCAVATIONS SHALL BE CLEANED BEFORE CONCRETE IS PLACED. ALL WATER OR OTHER DELETERIOUS MATERIALS AND LOOSE SOIL SHALL BE REMOVED FROM THE EXCAVATIONS PRIOR TO CONCRETE PLACEMENT. CONCRETE SHALL BE PLACED IN ALL FOOTINGS ON THE SAME DAY IN WHICH THEY ARE EXCAVATED AND MEASURES TO PREVENT EXCESSIVE DRYING OR MOISTENING OF THE EXCAVATION DURING THE TIMES OPENED SHALL BE TAKEN BY THE CONTRACTOR.
 - ALL FILL MATERIAL SHALL BE FREE OF ANY ORGANICS, CLAY BALLS OR OTHER DELETERIOUS MATERIALS. IN GENERAL ONLY SELECTED FILL WITH A P.L. LESS THAN OR EQUAL TO 15 SHALL BE ACCEPTABLE WITH SPECIFIED COMPACTION (ASTM D698).
- CAST-IN-PLACE CONCRETE**
- ALL CONCRETE WORK SHALL BE IN ACCORDANCE WITH THE BUILDING CODE REQUIREMENTS FOR REINFORCED CONCRETE, ACI 318, LATEST EDITION.
 - ALL CONCRETE FOR STRUCTURES (BEAMS) SHALL BE NORMAL WEIGHT SAND AND GRAVEL AGGREGATE. CONCRETE WITH A MINIMUM 28 DAY COMPRESSIVE STRENGTH OF 3000 PSI. CONCRETE MIX SHALL BE 8 BAGS OF CEMENT PER CUBIC YARD. CONCRETE STRENGTHS FOR THE AVERAGE OF ONE PAIR OF STRENGTH TESTS (CYLINDER BREAKS) THAT FALL BELOW THE REQUIRED MINIMUM SHALL BE CAUSE FOR REMOVAL OF PORTIONS OF THE WORK REPRESENTED BY THOSE TESTS.
 - THERE SHALL BE NO HORIZONTAL JOINTS IN CONCRETE WORK, OTHER THAN THOSE SPECIFICALLY SHOWN, AND ALL CONSTRUCTION JOINTS SHALL BE APPROVED BY THE ARCHITECT OR ENGINEER. ANY STOP IN CONCRETE PLACEMENT SHALL BE MADE WITH VERTICAL BULKHEADS INCORPORATING A SHEAR KEY AT THE CENTER OF SPANS BUT ONLY UPON THE APPROVAL OF THE STRUCTURAL ENGINEER.
 - FORMWORK DESIGN IS THE RESPONSIBILITY OF THE CONTRACTOR AND SHALL NOT BE REMOVED UNTIL THE CONCRETE HAS REACHED SUFFICIENT STRENGTH TO CARRY ITS OWN WEIGHT. REMOVAL OF BOTTOM FORMS ON GRADE BEAMS SHALL BE APPROVED BY THE ARCHITECT OR ENGINEER. ADDITIONAL STRENGTH TEST CYLINDERS MAY BE ADVISABLE TO CERTIFY ACCEPTABLE STRENGTH TEST FOR FORM REMOVAL. IN NO CASE SHALL BOTTOM FORMS, IF REQUIRED, BE REMOVED PRIOR TO 7 DAYS AFTER PLACEMENT OF CONCRETE.
 - UNLESS OTHERWISE NOTED, CONCRETE COVER FOR REINFORCING STEEL SHALL BE:
GRADE BEAM BOTTOMS 3"
GRADE BEAM SIDES 3"
GRADE BEAM TOPS 1 1/2"
FLOOR SLABS 1 1/2"
 - ALL PENETRATIONS AND SLEEVED HOLES SHALL BE APPROVED BY THE STRUCTURAL ENGINEER.
 - CHAMFER ALL EXPOSED CORNERS 3/4" OR AS SHOWN ON DRAWINGS.
- REINFORCING STEEL**
- ALL REINFORCING STEEL SHALL BE NEW BILLET DOMESTIC DEFORMED BARS CONFORMING TO ASTM A-615, GRADE 60 EXCEPT THAT #3 OR #4 BARS WHICH ARE BENT, (STIRRUPS, TIES OR DOWELS), MAY BE GRADE 40. GRADE MARKS SHALL BE PLAINLY EVIDENT ON ALL GRADE 60 BARS. ALL REINFORCING SHALL BE FREE OF RUST OR MILL SCALE AND SHALL BE STORED ABOVE THE GROUND.
 - DETAILS AND FABRICATION OF REINFORCING BARS SHALL BE IN ACCORDANCE WITH THE MANUAL OF STANDARD PRACTICE, ACI 315, LATEST EDITION, UNLESS SHOWN OTHERWISE. LAP CONTIGUOUS BARS 36 BAR DIAMETERS, OR A MINIMUM OF 24" AT SPLICES. LAP SPLICE BEAM TOP REINFORCING AT MID-SPAN BOTTOM REINFORCING OVER PIERS OR SUPPORTS.
 - REINFORCING BARS MAY NOT BE WELDED OR OTHERWISE HEATED FOR CUTTING WITHOUT APPROVAL OF THE STRUCTURAL ENGINEER.
 - ALL TOP AND BOTTOM REINFORCEMENT SHALL HAVE 2-#5, 24" x 24" CORNER BARS PLACED WITHIN THEM THAT EXTEND INTO ADJACENT BEAMS AT EXTERIOR CORNERS AND INTERIOR AND EXTERIOR TEES.
 - ALL STIRRUPS SHALL BE CLOSED STIRRUPS, AND ALL SPACINGS START AT 5/2 FROM THE CENTERLINE OF THE SUPPORT.
 - ALL TOP BARS SHALL BE HOOKED AT DISCONTINUOUS ENDS.
 - PROVIDE NECESSARY TIES AND BAR SUPPORTS AS REQUIRED BY THE MANUAL OF STANDARD PRACTICE, ACI 315, LATEST EDITION. BRACKETS OR OTHER MASONRY OR WOOD ARE NOT ACCEPTABLE SUPPORTS. CHAIRS AND BOLSTERS FOR APPLICATION DIRECTLY OVER EARTH POLY-SHEETS, OR FELTS SHALL BE EQUIPPED WITH BOTTOM BEARING PLATES.
 - ALL REINFORCING STEEL SHALL BE FREE FROM ANY BOND REDUCING COATING.
 - ALL HOOKS REQUIRED FOR REINFORCING SHALL BE 90 DEGREE HOOKS, UNLESS OTHERWISE SPECIFIED OR APPROVED. HOOKS SHALL BE PROVIDED AT ALL DISCONTINUOUS ENDS AND FOR ALL BARS AT CANTILEVERS.
 - CONCRETE COVER FOR THE REINFORCING STEEL SHALL COMPLY WITH ACI 318, LATEST EDITION, ARTICLE 7.7.1, EXCEPT WHERE SPECIFICALLY STATED OTHERWISE, FLOOR SLABS
 - WHERE OPENINGS IN OR PENETRATIONS THROUGH SLABS OR TOPPING SLABS FORM INSIDE CORNERS, PROVIDE DIAGONAL REINFORCING (2-#5 x 4'-0" LONG) ACROSS THE CORNERS, EXCEPT WHERE SHOWN OTHERWISE. THIS REINFORCING SHALL BE PLACED 1 1/2" BELOW THE TOP SURFACE OF THE SLAB.

IT IS OF UTMOST IMPORTANCE TO LANDSCAPE THE AREA AROUND THE STRUCTURE SUCH THAT WATER DRAINS RAPIDLY AWAY FROM THE BUILDING AND PAVEMENT. TO ACCOMPLISH THIS THERE SHOULD BE A MINIMUM OF SIX (6) INCHES OF FALL IN THE FIRST TEN (10) FEET AWAY FROM THE STRUCTURE IN ALL DIRECTIONS. PROPER DRAINAGE MAY BE ACHIEVED WHEN THE FINISH FLOOR ELEVATION IS SET A MINIMUM OF TWELVE (12) INCHES ABOVE THE HIGHEST EXISTING GRADE ELEVATION UNDER THE PERIMETER OF THE STRUCTURE. WATER MUST NEVER BE ALLOWED TO COLLECT OR POND NEXT TO THE FOUNDATION.

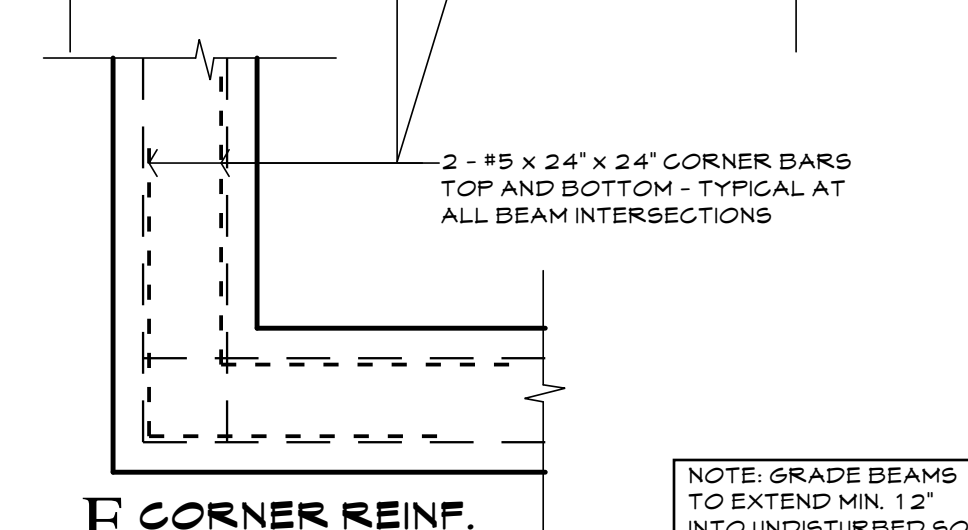
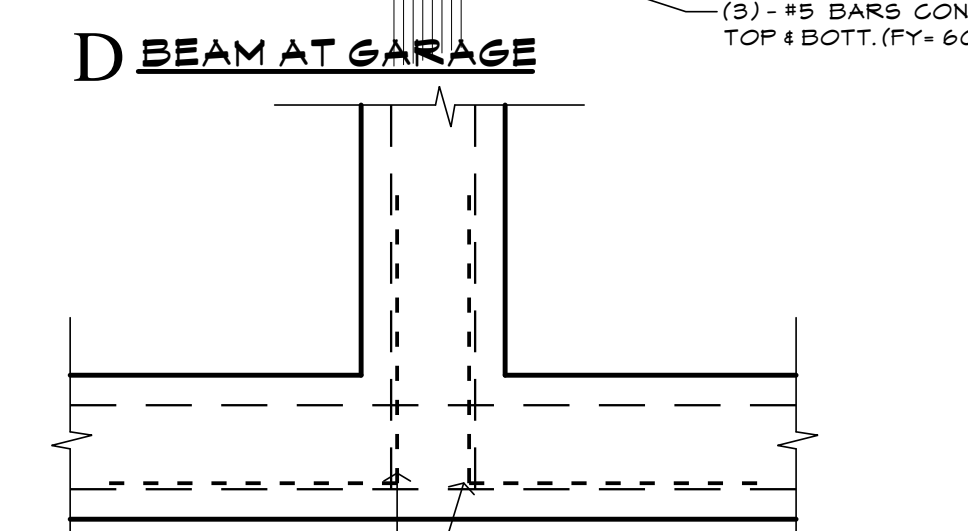
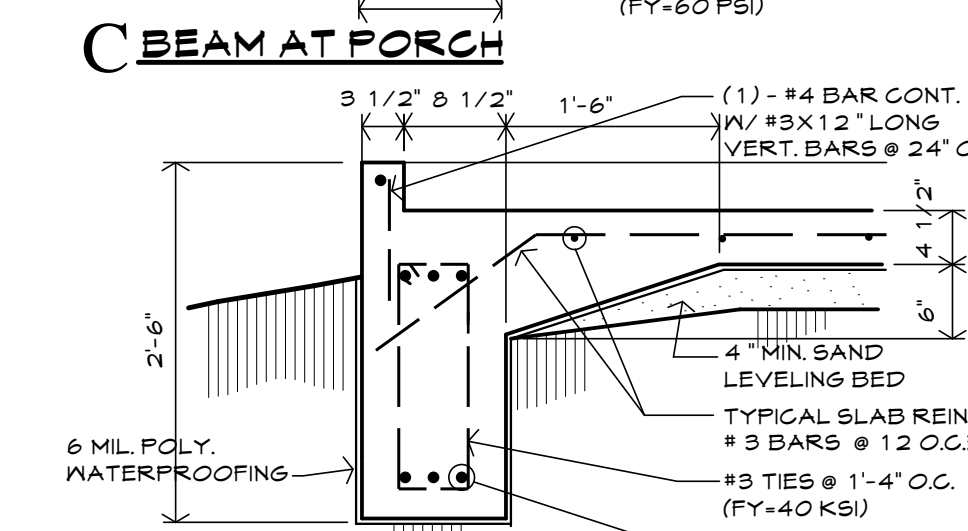
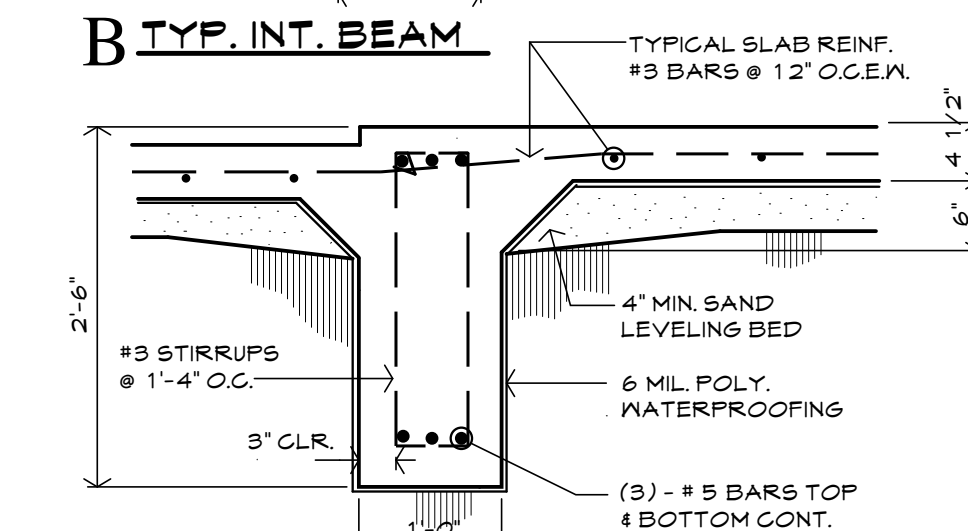
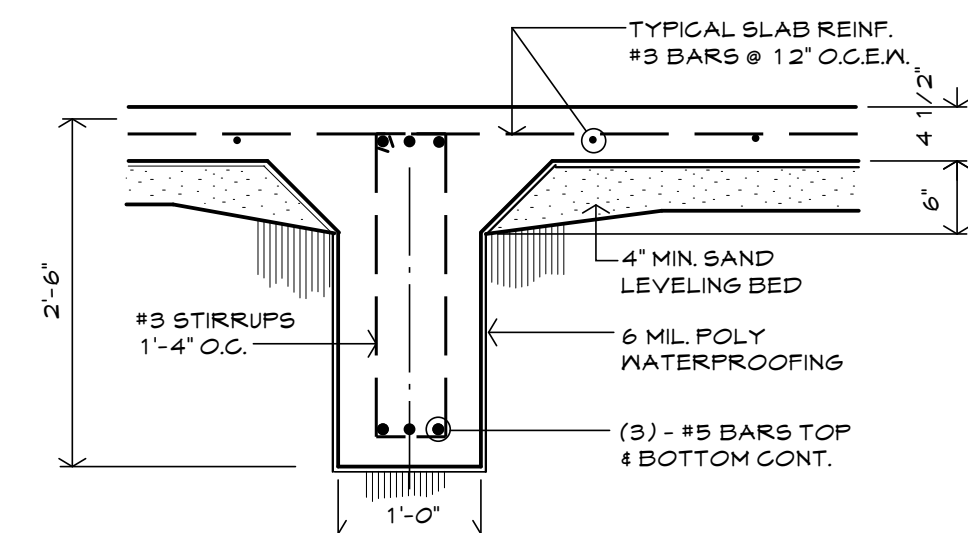
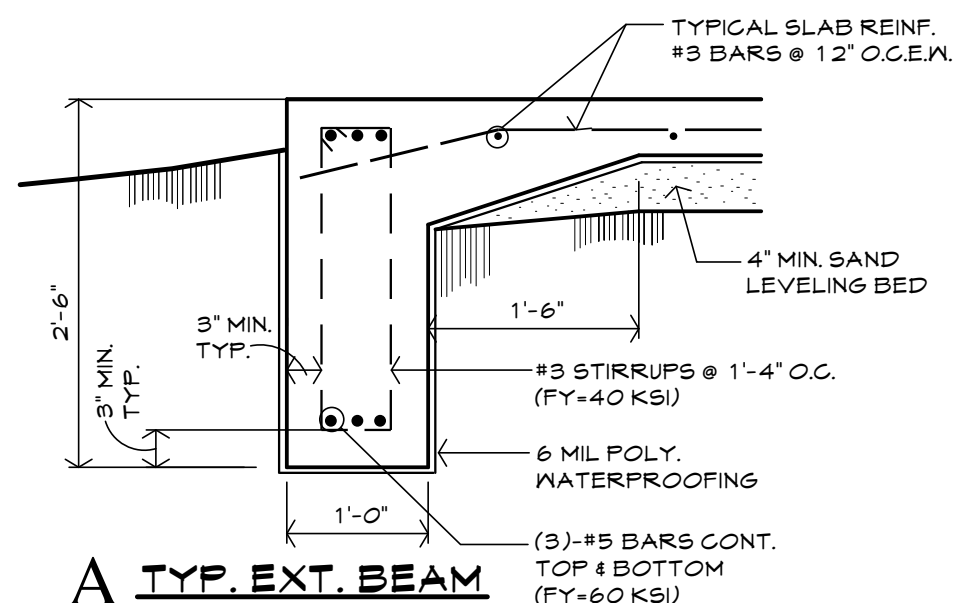

2 FOUNDATION DETAILS
SCALE: 3/4" = 1'-0"

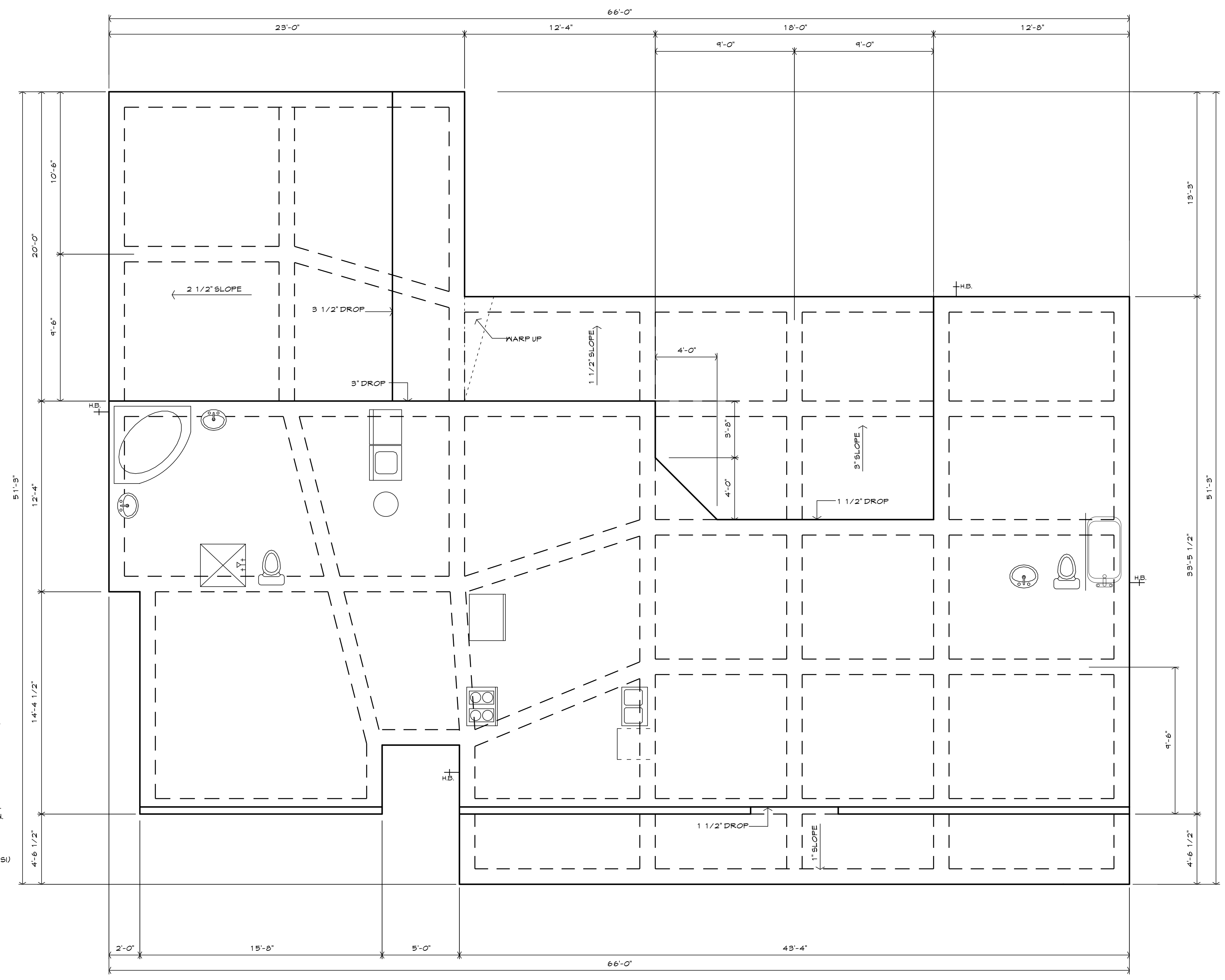

1 FOUNDATION PLAN

1/4" = 1'-0"

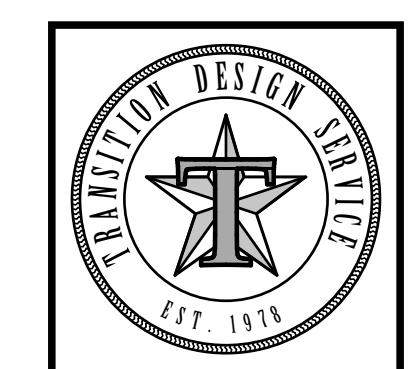

A NEW HOME FOR
JAMES YOUNG
COLLEGE STATION TEXAS
Transition Design Service
201 W. Villa Maria Road * Bryan, Texas 77801 * (979) 822-7777

DATE JAN. 2013
S 1